

# The JA-80V LAN / PSTN line communicator

The communicator is a component of the Jablotron Oasis 80 system. It is designed to be installed within the control panel housing. When connected to a PSTN telephone line and LAN (Ethernet) data network it allows the following:

- event reporting by SMS (to up to 8 telephone numbers)
- event reporting by phone call with an acoustic warning
- event reporting to an ARC (Automatic Receiving Centre – also known as a Central Monitoring Station) - up to 2 ARCs
- remote control and programming by phone (remotely authorizing a phone keypad or by SMS instructions)
- the remote control of appliances in a house by dialling in from an authorized number (free of charge with unanswered calls)
- remote control and programming via the Internet ([www.GSMlink.cz](http://www.GSMlink.cz))

The communicator can also be connected only to a telephone line or only to a LAN network. In these cases it will provide the following functions:

- **tel. line only:** remote control by phone, event reporting by SMS and by phone calls and event reporting to ARC2 (CID protocol)
- **LAN only:** remote access via the Internet, event reporting to ARC1 (IP CID protocol)

## 1. Installation in the control panel

If you purchased the communicator module separately, it should first be installed in the Oasis control panel as follows:

- The control panel **power must be switched off** (both mains and battery)
- Fit the communicator** inside the control panel housing using screws and **connect its digital bus RJ cable** to the main board
- Connect the PSTN telephone line cable** – the telephone line should support CLIP protocol (EN 300 089 V3.1.1) with Caller ID recognition and SMS transfer in text format activated (contact your phone line provider for more details).

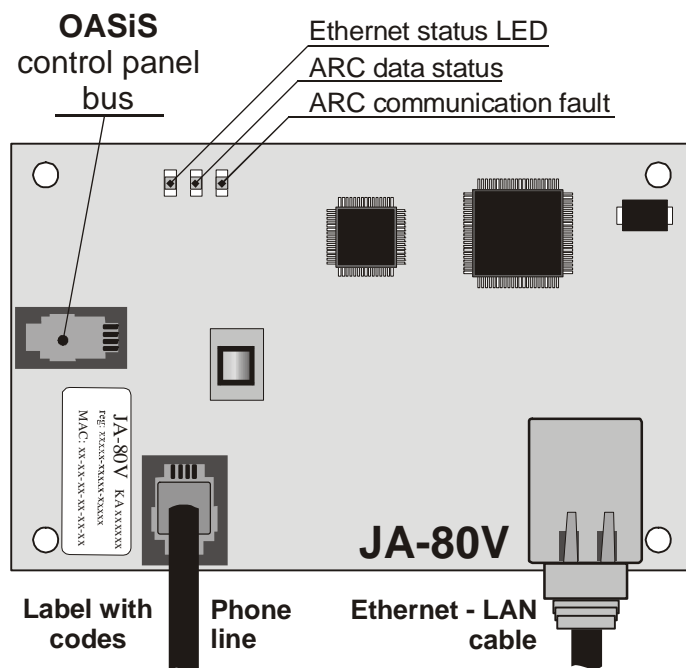

Fig. 1 Communicator wiring

## 2. Powering up the communicator for the first time

If the communicator is installed in the control panel then:

- Have the LAN (Ethernet) cable ready**
- Switch on the control panel power** (mains and battery). The communicator's **green LED** should turn on = no events to send to the ARC.
- If your LAN network does not provide an automatic DHCP, program the **Ethernet network parameters** manually (see 5.16).
- connect the LAN cable** (10/100 Mbit). If communication with the network is correct the yellow LED will be constantly lit.

If it starts flashing, check the DHCP parameters, if it turns off (after 3 sec. of flashing) then the communicator is not connected to the Ethernet at all.

- If communication to an ARC is desired, then all ARC parameters have to be programmed according to the ARC provider's specifications.
- Close the control panel cover**

## 3. User functions of the communicator

The following text describes all communicator features. The installer should show the end user how to operate the functions used in a particular installation.

### 3.1. Temporarily authorizing a phone keypad to be a system keypad

It is possible to operate the system remotely by temporarily authorizing a phone keypad as follows:

- dial the system's phone number**
- after 25 seconds** of ringing (programmable) the system will answer with a **short beep**
- key in a valid access code** on the telephone keypad (e.g. 8080 or 1234 if factory default settings are still valid)
- the phone keypad will behave as a system keypad and an **acoustic signal** in the receiver will indicate the control panel status: 1 beep = SET, 2 beeps = UNSET, 3 beeps = Service mode, 4 beeps = incorrect code entry, siren sound = alarm
- now the system **can be operated from the phone keypad** the same way as from the system keypad – including the commands starting with \* (for example \*81 to turn the PGX output on)
- to exit** this mode simply **end the phone call** (if nothing is entered within a minute, the phone call will end automatically anyway)

#### Notes:

- **do not enter sequences on the phone too fast**, each key signal needs a certain time to be sent
- a **fixed-line phone can also be used** to operate the system remotely the same way (the phone must use tone dialling)
- Phone keypads have to be re-authorized each time the system is called by entering the codes specified earlier, as phone keypads are only authorized as system keypads for the duration of a call to the system.

### 3.2. SMS instructions to control the system remotely

The telephone line connected to the communicator is used to receive SMSes but has to support CLIP protocol for SMS transfer in text form for this feature to work. The SMS transfer parameters should also be programmed – see 5.10 and 5.11.

All incoming SMSes are checked by the communicator and if there are any instructions to the system, they will be performed. Each instruction message must have the following format:

**code \_ instruction**

(valid code space instruction)

Valid code = any valid code in the system (e.g. 8080, 1234 etc.)

The factory-default instruction texts (editable – see 5.3)

Instruction	Function	Notes
SET	setting (arming)	setting or unsetting (the same way as if the code used is entered on the system keypad), If the system is already in the desired mode, it will not change
UNSET	unsetting (disarming)	
STATUS	status interrogation	including ARC communication (shown as MS1 and MS2)
MEMORY	last event interrogation	The last event recorded in the control panel memory
PGX ON	turns on PGX	the PG output has to be programmed for the function: on/off (by 237/247) or 2 second switching (by 238/248)
PGX OFF	turns off PGX	
PGY ON	turns on PGY	
PGY OFF	turns off PGY	

**Example:** by sending: "code SET" (valid code space SET) the system will set (if it is already set it will not change its status)

#### Notes:

- performance of the instruction is confirmed by an SMS reply
- the instruction texts are not case-sensitive and only ASCII characters are allowed
- only one instruction can be in an instruction SMS

- a setting/unsetting instruction starting with the service code will only be performed if setting/unsetting with the service code is enabled in the control panel (to protect against unauthorized setting/unsetting by installers)
- if there is any other text in the instruction not separated by "%", the instruction will not be performed
- if you are sending an instruction and you are not sure whether any other text will be automatically added to the SMS (for example, when using an SMS internet gate) type the instruction as: **%code instruction%%**
- no other device receiving SMSes can be connected to the same telephone line as the communicator.

### 3.3. Toll-free remote control by unanswered calls from pre-authorized phones

If the telephone line provides CLIP protocol caller ID, then a limited number of system functions can be activated remotely by calling the system from pre-authorized phones and terminating calls before the system answers. This way limited control of the system is free of call charges. It is possible to pre-authorize phone numbers stored in memories M1 to M8 (also used for event reporting – see 4).

To pre-authorize a telephone number store \* at the end of the number and follow it by a single digit (1, 2, 3, 8 or 9) – see the notes in section 4.

If this number calls, the communicator generates “\* digit” after the first ring (as if it had been entered manually on the system keypad). This toll-free remote control by unanswered calls enables the following functions according to the digit stored at the end (after the \*) of the tel. number in memory:

- \*1 **setting the complete system** (= ABC keypad button)
- \*2 **setting section A** (= A button)\*
- \*3 **setting sections A & B** or B (= B button)\*
- \*8 **PGX turns on for 2 sec.** (if PGX is programmed for the pulse function)
- \*9 **PGY turns on for 2 sec.** (if PGY is programmed for the pulse function)

#### Notes:

- if a phone sends no **caller identification data** it cannot be used for this type of remote control by phone
- if phone calls end before the control panel answers, remote control is **for free**
- a phone which is pre-authorized for toll-free remote control **can also temporarily authorize its keypad to fully** operate the system (see 3.1) – just let it ring until the control panel answers the call
- if it is desired that the phone which is authorized for toll-free remote control should **not receive event reports**, then turn the reports off for that tel. number (see 5.2).
- setting (arming) with \*1, \*2 and \*3 will work only if enabled in the control panel

## 4. Reporting to phones

The communicator can report events occurring in the Oasis system by sending SMS reports (if the telephone line supports CLIP protocol SMS transfer) and/or by calling phone numbers with an acoustic signal (mostly used as audible notification of an SMS to be read). Reporting can be programmed for **up to 8 phone numbers**.

The most frequently desired reports are already assigned to the telephone number memories by factory-default, so you only need to program tel. numbers to the particular memories which have the desired reports already assigned. If desired, other events can be reported to the number too, i.e. the list of event reports assigned to the number can be changed (see 5.2)

Factory-default reports assigned to the numbers M1 to M8

M	Reports
1	<b>Alarms and faults by SMS</b>
2	
3	<b>Alarms and faults by SMS + phone call</b> (if you answer the call you hear a siren sound)
4	
5	<b>Alarms by SMS + a phone call, with Setting/Unsetting and faults by SMS only</b>
6	
7	<b>Alarms by phone call</b> (if you answer the call you hear a siren sound)
8	<b>Technical fault by SMS</b> (suitable for an installer)

To program phone numbers to the M memories, enter the following sequence while in Service mode:

**81 M xxx...x \*0**

where:

**M** is memory 1 to 8

**xxx...x** is a phone number (max. 20 digits)

**Example:** entering **81 5 777 777 777 \*0** will store the number **77777777** in memory M5 (Alarms will be reported by SMSes + phone calls, Setting/Unsetting and faults only by SMS)

To erase a number from memory M enter: **81 M \*0**

#### Notes:

- international phone numbers have to start the same way as if you call them from the phone line which is connected to the communicator.
- **SMS report text consists of:** installation name, event name, number and name of the event source (device or code), date and time. Example: “Report from your alarm: setting 47: device Time 01.08. 11:27”
- if **other events or texts should be reported** to a particular number, change the communicator settings (see 5.2 and 5.3)
- when storing tel. numbers, if you key in \*7 after the last digit of the phone number (the symbol \* is also stored) and continue with one more digit (1, 2, 3, 8 or 9), then if this tel. number calls the system, the system will behave as if “\* digit” had been keyed in just after the first ring, i.e. as if it had been entered manually on the system keypad – see section 3.3. Example: entering **81 5 777 777 777 \*79 \*0** authorizes calls from tel. number **77777777** to trigger output **PGY** for 2 seconds (after the first ringing signal from this number the \*9 command will be executed. The **PGY** output should be programmed for a 2 sec. pulse function. This setting is suitable for opening an electric door lock, automatic gate etc.

### 4.1. Programming

The most convenient programming is best done by a PC running Comlink software or via the Internet and website: [www.GSMLink.cz](http://www.GSMLink.cz)

Programming is also possible via the system keypad:

- The control panel must be in **Service mode** - if it is not, enter \*0 Service code (factory default: 8080) while the system is unset.
- Enter the relevant programming sequences – see the following description
- **To exit service mode** press the # key

## 5. Programming sequences

Function	Sequence	Options	Factory default
<b>Tel. number programming for reporting to telephones</b>	<b>81 M xx..x *0</b>	<b>M</b> = memory 1 to 8 <b>xx..x</b> = tel. number (max.20 digits) keying in *7 = * <b>81 M *0</b> erases the number in memory M	all M1 to M8 erased
<b>Selection of events to report by SMS</b>	<b>82 M ec x</b>	<b>M</b> = tel. number memory from 1 to 8 <b>ec</b> = event code (see 5.2)	M1 & 2 alarms by SMS M3 & 4 alarms by SMS and call M5 & 6 alarms by SMS and call + Set/Unset by SMS
<b>Selection of events to report by phone call</b>	<b>83 M ec x</b>	<b>x=1</b> report, <b>x=0</b> no report	M7 alarms by call M8 technical faults by SMS (to installer)
<b>SMS/phone call communication checking period</b>	<b>84 hhmm</b>	hhmm = hours and minutes in range from 00:00 to 24:00 (The time to wait after the last SMS/phone call report before performing an SMS/phone	24:00

		communication check)	
<b>SMS text editing*</b>	Texts can be edited by Comlink software or by SMS instruction: <b>code TXT n,text,n,text...</b> or by <a href="http://www.GSMLink.cz">www.GSMLink.cz</a> via Internet		see 5.3
<b>Enable reporting to phones</b>	<b>80 x</b>	x=0 disabled x=1 enabled (all programmed by 82.. & 83..) x=2 enabled <b>without reporting setting/unsetting by users 41 to 50</b> (codes, cards & key-fobs) and master code setting/unsetting x=3 only if ARC1 is not responding x=4 only if ARC1 is not responding	x=1 enabled
<b>Phone number for instant remote access</b>	<b>902 xx..x *0</b>	xx..x = tel. number (max.20 digits)	erased
<b>Remote access</b>	<b>903 x</b>	x=0 disabled x=1 enabled (by phone and Internet)	enabled
<b>Forwarding of incoming SMSes</b>	<b>926 x</b>	x=0 no, x=1 yes = if the incoming text is not an SMS instruction it will be forwarded to the first programmed number in memories M1 to M8	yes
<b>Reaction to incoming calls</b>	<b>904 x</b>	x=0: no reaction x=1 to 8: answers after 1 to 8 rings x=9: answers after the 2 <sup>nd</sup> call	answers after 5 rings (25s)
<b>Initialisation of GSMLink communication</b>	<b>913</b>	initialises communication to GSMLink	
<b>Tel. number to initialise GSMLink communication</b>	<b>914 xx..x *0</b>	xx..x = tel. number (max.20 digits)	erased
<b>Tx SMS center tel. number</b>	<b>942 xx..x *0</b>	xx..x = tel. number (max.20 digits)	erased
<b>Rx SMS center tel. number</b>	<b>943 xx..x *0</b>	xx..x = tel. number (max.20 digits)	erased
Testing reporting to an ARC	<b>961 a</b>	a=1=ARC1, a=2=ARC2	
<b>Test calls to a phone number</b>	<b>962 M</b>	M = tel. number memory from 1 to 8	
<b>Triggering LAN re-log-in</b>	<b>935</b>	The communicator will log out of the LAN network and then re-log-in (DHCP update)	
<b>Communicator reset</b>	<b>98080</b>	Resets to the factory default settings and erases all phone numbers	
<b>Automatic DHCP</b>	<b>930 x</b>	x=0 disabled x=1 enabled	enabled
<b>Communicator IP address</b>	<b>931 xx..x</b>	xx..x = IP address 12 digits (if automatic DHCP disabled)	192.168.001.211
<b>Network mask</b>	<b>932 xx..x</b>	xx..x = network mask 12 digits (if automatic DHCP disabled)	255.255.255.0
<b>Network gateway address</b>	<b>933 xx..x</b>	xx..x = IP address 12 digits (if automatic DHCP disabled)	192.168.001.001
<b>DNS IP address</b>	<b>934 xx..x</b>	xx..x = IP address 12 digits (if automatic DHCP disabled)	192.168.001.001
<b>ARC main tel. number/IP address</b>	<b>01 a xx..x *0</b>	a=1=ARC1, a=2=ARC2, xx..x = <b>IP address &amp; port</b> for ARC1 – e.g. 01 2 *8 192 168 001 123 08080 *0 (*8= signifies an IP address, it must have 12 digits followed by a 5 digit port number).	erased
<b>ARC backup tel. number/IP address</b>	<b>02 a xx..x *0</b>	<b>Tel. number</b> for ARC2 (max.20 digits) Entering 01p*0 or 02p*0 will erase the number/address	
<b>Installation (alarm system) ID for ARC use</b>	<b>03 a zz..z *0</b>	a=1=ARC1, a=2=ARC2, zz..z = ID number max. 8 digits 0 to 9 and *1=A to *6=F (hexadecimal number)	0000
<b>Selection of events to report to ARCs</b>	<b>05 a ec x</b>	a=1 ARC1, a=2 ARC2 <b>ec</b> event code (see 5.23) <b>x=1</b> report, <b>x=0</b> no report	all events are reported
<b>Defining the delay before data is resent to an ARC</b>	<b>06 a x</b>	a=1 ARC1, a=2 ARC2 x=0 to 9 min. (0=immediately, without delay)	1 minute
<b>ARC communication checking period</b>	<b>07 a hhmm</b>	a=1 ARC1, a=2 ARC2 hhmm = hours and minutes after last report (The time to wait after the last report before performing an ARC communication check)	2400 (24 hours after last report)
<b>Enable ARC reporting (ARC2 backs up ARC1)</b>	<b>00 a x</b>	a=1 ARC1, a=2 ARC2 x=0 reports disabled, x=1 reports enabled, x=2 (only for ARC2) = ARC2 backs up ARC1	ARC reporting disabled
<b>Recording reports sent to ARCs in the control panel memory</b>	<b>08 x</b>	x=0 no (only records ARC communication faults, if communication checks are enabled) x=1 yes (all reports except communication checks)	yes
<b>Indicate an ARC communication fault if a report is not successfully received by an ARC within 110</b>	<b>09 x</b>	x=0 no x=1 yes	no

<b>sec of transmission.</b>			
<b>Locking the ARC settings</b>	<b>901 xx..x *0</b>	xx..x = an installer-defined locking code (4 to 8 digits). Entering this code and then exiting service mode will lock the ARC settings <b>901*0</b> will erase the code (= <b>permanently unlocked</b> )	unlocked
<b>Unlocking the ARC settings</b>	<b>900 xx..x *0</b>	xx..x = a locking code used by sequence 901	ARC programming can be <b>temporarily enabled</b> in service mode by entering this sequence. It will then relock on exiting service mode

These parameters effect reporting to the ARC and it is impossible to change them if the ARC settings are locked.

\* These parameters cannot be programmed from the system keypad, but they can be programmed by sending SMS instructions or by Comlink software.

### 5.1. Programming tel. numbers for reporting to phones

See part 4.

### 5.2. Selection of the events reported to phones

The factory-default list of reported events and their assignment to telephone numbers M1 to M8 can be altered by this sequence.

- The complete list of reportable events is shown in the following table.
- It is possible to select whether the event should be reported by an SMS or by a phone call, or by both an SMS followed by a phone call
- Each event has pre-programmed factory-default SMS text. These texts can be edited (see 5.3). The acoustic signals for phone call reporting are fixed and cannot be changed (e.g. an alarm is indicated by a siren sound if a reporting call is answered)

#### List of events which can be reported to phones and their factory-default assignment to particular phone numbers

ec	Event	Phone number memory M							
		1	2	3	4	5	6	7	8
01	Intruder alarm - instant	S	S	SC	SC	SC	SC	C	
02	Intruder alarm - delayed	S	S	SC	SC	SC	SC	C	
03	Fire alarm	S	S	SC	SC	SC	SC	C	
04	Panic alarm	S	S	SC	SC	SC	SC	C	
05	Number of permitted incorrect code-entries exceeded	S	S	SC	SC	SC	SC	C	
06	Alarm triggered during control panel power-up	S	S	SC	SC	SC	SC	C	
07	Tamper alarm	S	S	S	S	S	S		
08	End of tamper alarm								
09	End of alarm indication								
10	Alarm cancelled by user	S	S	S	S	S	S		
11	Setting					S	S		
12	Unsetting					S	S		
13	Partial setting					S	S		
14	Codeless setting					S	S		
15	External communication fault	S	S	S	S	S	S		S
16	External communication restored								
17	Fault	S	S	S	S	S	S		S
18	Fault no longer present								
19	Mains dropout longer than 30 minutes	S	S	S	S	S	S		S
20	Mains dropout								
21	Mains restored								
22	Discharged battery	S	S	S	S	S	S		S
23	Battery OK								
24	Switching to Service Mode								
25	Leaving Service Mode								
26	PGX ON/OFF								
27	PGY ON/OFF								
28	Radio communication jamming present	S	S	S	S	S	S		S
29	Internal communication fault	S	S	S	S	S	S		S
30	Internal communication restored								
31	Communication test								
32	Unconfirmed alarm								

- Factory-default report assignment: **S** = SMS, **C** = call, **SC** = SMS followed by a call

### 5.2.1. Assigning events to be reported by SMS to a particular mobile phone number

To link events to being reported by SMS, enter:

#### 82 M ec x

where

- M** phone number memory 1 to 8
- ec** event code 01 to 32 (see the above table)
- x** **0** = no SMS report, **1** = SMS report

**Example:** if **82 8 03 1** is programmed and a fire alarm is triggered (event 03 in the table), it will be reported by SMS to the phone number stored in memory M8

### 5.2.2. Assigning events to be reported by phone call to a particular phone number

To link events to being reported by phone call, enter:

The JA-80V LAN / PSTN line communicator

#### 83 ec M x

where

- M** phone number memory 1 to 8
- ec** event code 01 to 32 (see the above table)
- x** **0** = no phone call, **1** = call

**Example:** if **82 1 03 1** is programmed and a fire alarm is triggered (event 03 in the table), the phone number stored in memory M1 will be called and if the call is answered, a siren sound will be heard.

#### Notes:

- Phone call reports are mostly used as an audible notification to alert the user of a detailed report sent by SMS
- If both SMS + call reports are enabled for events, the SMS is sent first and then the number is called afterwards. But total priority is given to ARC reports if enabled (see 7.1)

### 5.2.3. SMS/phone call communication checking period

A regularly sent communication checking SMS report and/or phone call to a telephone can be enabled as event code ec=31 (see table in 5.2).

This sequence programs how often the checking report should be performed:

**84 hhmm**

where

**hh** hours (00 to 24) to wait after the last SMS/phone call report  
**mm** minutes (00 to 59) to wait after the last SMS/phone call report

**Notes:**

- The **communication checking report** is not sent if the system is in service mode

**Factory default setting:** 24 hours from the last report

**5.3. SMS text editing**

The communicator contains various text strings which are used to create SMS reports and also SMS instruction text. These text strings cannot be changed from the system keypad, but they can be edited by Comlink software, via the Internet ([www.GSMLink.cz](http://www.GSMLink.cz)) or by sending the following SMS instruction:

**code\_TXT\_n,text,n,text,.....n,text**

where

**code** is a valid access code (e.g. factory defaults: 8080, 1234)

**\_** is a space

**TXT** instruction to edit texts

**n** text number (0 to 611 see the following table)

Factory-default SMS report and instruction texts

n	Factory text	n	Factory text	n	Factory text	n	Factory text
0	Report from your alarm:	44	Device	332	Code	503	Fire
1	Device	45	Device	333	Code	504	Panic alarm
2	Device	46	Device	334	Code	505	Invalid code-entries exceeded
3	Device	47	Device	335	Code	506	Alarm when power turned on
4	Device	48	Device	336	Code	507	Tamper alarm
5	Device	49	Device	337	Code	508	End of tamper alarm
6	Device	50	Device	338	Code	509	End of alarm indication
7	Device	201	Control panel	339	Code	510	Alarm cancelled by user
8	Device	202	Service code	340	Code	511	Setting
9	Device	203	Annual inspection request	341	Code	512	Unsetting
10	Device	204	Communicator	342	Code	513	Partial setting
11	Device	205	Keypad	343	Code	514	Codeless setting
12	Device	300	Master code	344	Code	515	External communication fault
13	Device	301	Code	345	Code	516	External comm. restored
14	Device	302	Code	346	Code	517	Fault
15	Device	303	Code	347	Code	518	Fault no longer present
16	Device	304	Code	348	Code	519	Mains dropout over 30 minutes
17	Device	305	Code	349	Code	520	Mains dropout
18	Device	306	Code	350	Code	521	Mains recovery
19	Device	307	Code	400	System status	522	Discharged battery
20	Device	308	Code	401	Set	523	Battery OK
21	Device	309	Code	402	Unset	524	Switching to Service Mode
22	Device	310	Code	403	Exit delay	525	Leaving Service Mode
23	Device	311	Code	404	Entrance delay	526	PGX
24	Device	312	Code	405	Alarm	527	PGY
25	Device	313	Code	406	Service mode	528	Radio jamming present
26	Device	314	Code	407	Maintenance mode	529	Internal communication fault
27	Device	315	Code	408	Partial setting	530	Internal comm. restored
28	Device	316	Code	409	Discharged battery	531	Communication test
29	Device	317	Code	410	Tamper alarm	532	Unconfirmed alarm
30	Device	318	Code	411	Alarm memory	601	SET
31	Device	319	Code	412	Fault	602	UNSET
32	Device	320	Code	413	Power fault	603	STATUS
33	Device	321	Code	414	Unknown status	604	MEMORY
34	Device	322	Code	415	Time:	605	PGX ON
35	Device	323	Code	416	Last event:	606	PGX OFF
36	Device	324	Code	417	Credit unknown	607	PGY ON
37	Device	325	Code	418	Credit:	608	PGY OFF
38	Device	326	Code	419	<i>not used</i>	609	AUX ON
39	Device	327	Code	420	Error while processing command	610	AUX OFF
40	Device	328	Code	421	Output turned on	611	CREDIT
41	Device	329	Code	422	Output turned off	<i>Numbers 01 to 50 for devices and codes are automatically generated by the communicator so it is unnecessary to enter them in the text</i>	
42	Device	330	Code	501	Instant alarm		
43	Device	331	Code	502	Delayed alarm		

- The communicator always automatically puts numbers from 01: to 50: in front of Device or Code names.
- Texts 0 to 532 are used to create SMS **event reports**
- Texts 601 and 611 are **SMS instructions** (to control the system remotely by SMS)

, comma (or full stop)

**text** the new text (max. 30 characters) which will replace the former text. It is invalid to enter a comma or a full stop inside the text string, but a space is valid within the text string

**Notes:**

- A single **TXT** instruction can change multiple texts (limited only by the maximum length of a single SMS)
- the communicator is not case-sensitive and it is recommended to use only English ASCII characters (some networks do not support non-English national characters)
- the communicator creates SMS reports with 5 parts: installation name, event description, source (code or device) number (01 to 50), source name, time and date
- the maximum possible length of an ASCII SMS is 160 characters (only 70 characters for national characters). If this length is exceeded, the report is sent as multiple SMSes

**Examples:** if the service code is 8080 then the SMS instruction:

**8080 TXT 20,key fob Bob,21,Key fob Jane**

changes the description (name) of the key fobs enrolled to addresses 20 and 21

**8080 TXT 605,heating on,606,heating off**

edits the text of the two instructions used to command the heating to be switched on and off by the PGX output (the PGX output must be programmed to have an ON/OFF function)



#### 5.4. Enabling reporting to phones

Event reports can be enabled as follows:

- 800** all SMS and call reports disabled
- 801** all SMS and call reports enabled
- 802** all reports enabled **except reports of setting and unsetting by users 41 to 50** (i.e. their codes, cards and key fobs). This allows setting and unsetting done by report recipients (owners, bosses, etc.) not to be reported.
- 803** all SMS and call reports enabled if ARC1 is not responding
- 804** all SMS and call reports enabled if ARC2 is not responding

**Factory default setting:** 801 all reports enabled

#### 5.5. Phone number for instant remote access

A telephone number programmed with this sequence allows instant remote access no matter what reaction to incoming calls is programmed. If this number calls, the control panel will answer the call after the first ring (the telephone line must provide CLIP protocol caller ID for this feature).

**902 xx...x \*0** where xx...x = phone number

**Note:**

- if remote access is disabled (see 5.6), then using this phone number for remote access is also disabled.

**Factory default setting:** erased

#### 5.6. Remote access

Remote access (by phone or Internet) can be enabled or disabled:

- 9030** disabled
- 9031** enabled

**Factory default setting:** enabled

#### 5.7. Forwarding of incoming SMS messages

This feature enables the automatic forwarding of incoming SMS messages which contain no valid instructions to the system:

- 9260** messages are not forwarded (will not be used)
- 9261** messages **are forwarded** to the first programmed tel. number in memories M1 to M8 (e.g. if numbers are only programmed in M5 and M6, then messages will be forwarded to M5). The tel. number from which the SMS was received will be shown at the beginning of the forwarded text.

**Factory default setting:** messages are forwarded

#### 5.8. Reaction to incoming calls

The communicator's reaction to incoming phone calls can be set by:

- 904 x**  
where
- x = 0 incoming calls are ignored
  - x = 1 to 8 the communicator will answer after x multiplied by 5 seconds of ringing (e.g. x=4=20sec.)
  - x = 9 answers after a second call - first there must be at least one ring, then a pause (10 to 45sec.) and then just after the first ring of the second call, the call will be answered

**Factory default setting:** 935 – answers after 25 sec. (about 5 rings)

#### 5.9. Initialization of GSMLink communication

After successfully connecting the communicator to the LAN network **913** should be entered to initialise communication to the [www.GSMLink.cz](http://www.GSMLink.cz) server (the server will register the IP address of the communicator).

To access the system remotely via the Internet it is necessary to register it on [www.GSMLink.cz](http://www.GSMLink.cz) (after communication has been initialised). To register the system (see 7.5) you will need the

communicator registration code, which is printed on the label which you will find on the communicator board.

**Note:**

- the communicator reports regularly to the GSMLink server to update the communicator's IP address in the server database (the period of the regular reports is more frequent the more frequently GSMLink access is used). If you try to access the alarm system via GSMLink after the communicator's dynamic IP address has changed, you can be notified by GSMLink that it is necessary to wait for the next regular communication from the system. To shorten this waiting time you can enter the above sequence (913) on the system keypad while in service mode or you can do it remotely by calling the communicator from a phone, whose number was programmed for this purpose (see the following text).

#### 5.9.1. Tel. number to initialise GSMLink communication

GSMLink communication can be initialised remotely by calling (ringing) from a phone number which can be programmed by:

**914 xx...x \*0** where xx...x = phone number (max. 20 digits)

**Notes:**

- After the first ring from the above programmed number the communicator will report to GSMLink to update its IP address,
- this remote way of initialisation is only possible if the phone line used by the communicator supports CLIP caller ID recognition).

**Factory default setting:** erased

#### 5.10. Tx SMS center telephone number

To send SMS by CLIP protocol via the telephone line it is necessary to program the Tx SMS center telephone number by:

**942 xx...x \*0** where xx...x = Tx SMS center tel. number

**Note:**

- Contact your telephone line provider to learn the Tx SMS center tel. number.

**Factory default setting:** erased

#### 5.11. Rx SMS center telephone number

To receive SMS by CLIP protocol via the telephone line it is necessary to program the Rx SMS center telephone number by:

**942 xx...x \*0** where xx...x = Rx SMS center tel. number

**Note:**

- Contact your telephone line provider to learn the Rx SMS center tel. number,
- check also how to activate delivery of the SMSes in text form (some providers convert SMS text into voice messages).

**Factory default setting:** erased

#### 5.12. Testing reporting to an ARC

To test reporting to an ARC enter:

**961a** where a = ARC number (1 or 2)

**Note:**

The event code "Communication test" (ec=31) will be sent to the ARC. The green LED flashes while the report is being sent, if the red LED goes off it indicates that the report to the ARC was unsuccessful.

#### 5.13. Testing calls to a phone number

To test that the communicator is capable of calling the phone numbers programmed into its memories enter:

**962M** where M is the phone number memory 1 to 8

If memory M contains a phone number, this number will be called and if the phone call is answered, there will be an acoustic signal.

#### 5.14. Triggering LAN re-login

After entering **935** the communicator will log out of the LAN network and then re-log in (DHCP updates).

### 5.15. Communicator reset

Entering **98080** returns the communicator to its factory default settings and texts, erases all telephone numbers and disables reporting.

### 5.16. Automatic DHCP

The factory default settings in the communicator expect automatic DHCP in the LAN network. If you need to enter the network parameters manually, the automatic DHCP should be disabled with this sequence and network parameters should be entered manually by the following sequences before the communicator is connected to the LAN network.

**9300** DHCP disabled  
**9301** DHCP enabled

**Factory default setting:** *enabled*

### 5.17. Communicator IP address

If DHCP is disabled (see 5.16) program the communicator IP address by:

**931 xxx xxx xxx xxx**

where:  
**xxx...x** is IP address

**Example:** if the IP address is 192.168.1.23 enter:  
931 192 168 001 023

**Factory default setting:** 192.168.001.211

### 5.18. Network mask

If DHCP is disabled (see 5.16) program the network mask by:

**932 xxx xxx xxx xxx**

where:  
**xxx...x** is the network mask

**Example:** if the network mask is 255.255.255.0 enter:  
932 255 255 255 000

**Factory default setting:** 255.255.255.000

### 5.19. Network gateway address

If DHCP is disabled (see 5.16) program the network gateway by:

**933 xxx xxx xxx xxx**

where:  
**xxx...x** is the gateway address

**Example:** if gateway address is 192.168.33.1 enter:  
933 192 168 033 001

**Factory default setting:** 192.168.001.001

### 5.20. DNS IP address

If DHCP is disabled (see 5.16) program the network DNS IP address by:

**934 xxx xxx xxx xxx**

where:  
**xxx...x** is the DNS address

**Example:** if the DNS address is 192.168.33.1 enter:  
933 192 168 033 001

**Factory default setting:** 192.168.001.001

### 5.21. ARC phone numbers / IP addresses

Events can be reported to up to 2 ARCs (which can be independent or ARC2 can work as ARC1's backup). The communicator reports to ARC1 via a LAN network using IP CID protocol and to ARC2 via the phone line using CID protocol. This sequence serves to enter an ARC's main and backup IP addresses / phone numbers:

Main: **01 a xx...x \*0**

Backup: **02 a xx...x \*0**

where:

The JA-80V LAN/PSTN line communicator

**a** 1=ARC1, 2=ARC2

**xxx...x** IP address and port for a=1 – entry format example:

**01 2 \*8 192 168 001 123 08080 \*0**

where **\*8** (auto-converts to #) signifies an IP address which must have 12 digits and must be followed by the 5 digits of the port number (no separators)

**tel. number** (max. 20 digits) for a=2

**To erase** a tel. number / IP address enter: **01p\*0** or **02p\*0**

If numbers / IP addresses are erased there will be no reporting to that particular ARC

**Notes:**

- the communicator first tries to send data to the main number / address, if it is not successful it tries the backup
- **IP CID is a fast** protocol and it also allows **very frequent checking of communication reliability** with the ARC (e.g. every 5 minutes)
- Contact ID protocol can be used with ARCs linked by standard telephone lines (if they support Contact ID)
- If your ARC does not allow IP CID protocols, please contact a Jablotron distributor for details on how to update your ARC.
- **Another way of backing up communication to an ARC** is a calling report to a particular number (see 5.2). This way up to 8 groups of events can be reported to an ARC. For this the ARC needs 8 phone lines which can recognize caller ID. By calling a particular ARC tel. number the communicator is communicating what happened (the kind of event). The ARC can recognize what happened by knowing which telephone line is being rung. By caller ID recognition it also knows what installation is reporting. The ARC does not answer the incoming calls on these telephone lines, so this simple kind of communication is free of charge. By using this method the ARC does not send any confirmation back to the communicator that the report was successfully received.

**Factory default setting:** *all tel. numbers / IP addresses erased*

### 5.22. Installation (alarm system) ID for ARC use

The installation's ID number which is sent to an ARC with every report can be programmed by:

**03 a zz..z \*0**

where:

**a** 1=ARC1, 2=ARC2

**zz..z** installation ID number, max. 8 characters (0 to 9 and \*1=A to \*6=F - hexadecimal number)

**Factory default setting:** *0000 for both ARCs*

### 5.23. Selection of events to report to ARCs

The system recognizes 32 different types of events - see the following table. This sequence allows you to select which events are reported to which ARC.

**05 a ec x**

where **a** 1 = ARC1, 2 = ARC2

**ec** event code 01 to 32

**x** 0 = no report, 1 = report

**Factory default setting:** *all events are reported*

ec	Event
01	Intruder alarm - instant
02	Intruder alarm - delayed
03	Fire alarm
04	Panic alarm
05	Number of permitted incorrect code-entries exceeded
06	Alarm triggered during control panel power-up
07	Tamper alarm
08	End of tamper alarm
09	End of alarm indication
10	Alarm cancelled by user
11	Setting
12	Unsetting
13	Partial setting
14	Codeless setting
15	External communication fault
16	External communication restored
17	Fault
18	Fault no longer present
19	Mains dropout longer than 30 minutes

20	Mains dropout
21	Mains restored
22	Discharged battery
23	Battery OK
24	Switching to Service Mode
25	Leaving Service Mode
26	PGX ON/OFF
27	PGY ON/OFF
28	Radio communication jamming present
29	Internal communication fault
30	Internal communication restored
31	Communication test
32	Unconfirmed alarm

Besides the events listed above, the communicator also reports some events which are not selectable here (e.g. the annual inspection request if enabled in the control panel = CID 1393)

#### 5.24. Defining the delay before data is resent to an ARC

The communicator tries to send reports to the main number / IP address, and if unsuccessful it then tries the backup number. If still unsuccessful, it then tries to re-send the data to both the ARCs again as before, but after a period defined by:

**06 a x**  
 where  
**a** 1 = ARC1, 2 = ARC2  
**t** is the period: 0=immediately, 1 to 9 = 1 to 9 minutes

**Factory default setting:** 1 min. for both ARCs

#### 5.25. ARC communication checking period

The time to wait after the last report sent to an ARC before performing an ARC communication check is set by this sequence. The communication-checking event code is 31 (see 5.23). This sequence programs how often the communication check is performed:

**07 a hhmm**  
 where  
**a** 1 = ARC1, 2 = ARC2  
**hh** hours  
**mm** minutes

#### Notes:

- Checking reports are not sent in service mode
- IP CID protocol allows **very frequent checking of ARC communication** (e.g. every 5 minutes).

**Factory default setting:** 24 hours after the last report – for both ARCs

#### 5.26. Enable ARC reporting (ARC2 backs up ARC1)

This sequence allows reporting to ARCs to be switched on/off and also enables ARC2 to backup ARC1:

**00 a x**  
 where  
**a** 1=ARC1, 2=ARC2  
**x** 0=off, 1=on, 2= ARC2 backs up ARC1 (2 can only be entered for ARC2)

**Note:** if ARC2 backs up ARC1 then it will only receive data if it is not possible to deliver it to ARC1. A report containing "Communication fault to ARC1" is then sent to ARC2 together with the first report to ARC2.

**Factory default setting:** both ARCs = off

#### 5.27. Recording reports sent to ARCs in the control panel memory

This sequence enables the recording of every report successfully communicated to ARCs in the control panel's internal memory.

**080** enabled  
**081** disabled

**Note:** it is recommended not to record reports sent to ARCs but to enable the indication of ARC communication faults (see 5.28). This saves a significant amount of control panel memory. The system initially assumes that every report is successfully delivered to ARCs, but if a report is not successfully delivered within 110 seconds of transmission, then a communication fault will be indicated and recorded.

**Factory default setting:** enabled

#### 5.28. Indicate an ARC communication fault if a report is not successfully received within 110 sec of transmission

Enables the indication and recording of a communication fault if a report is not successfully delivered to an ARC within 110 seconds of its transmission.

**090** communication faults not indicated  
**091** communication faults indicated

#### Notes:

- The communicator continues trying to send information to an ARC even after a communication fault has been indicated (after the data has been delivered, communication fault indication stops).
- For communication-checking reports the delivery time limit (confirmation from the ARC) is 300 minutes. But if any other report is sent to the ARC it must be confirmed within 110 seconds (otherwise a communication fault will be indicated)

**Factory default setting:** communication faults not indicated

#### 5.29. Locking the ARC settings

All settings which effect reporting to ARCs can be locked by a digital code:

**901 xx..x \*0** where xx..x is an installer-defined locking code (4 to 8 digits)

#### Notes:

- Exiting service mode after the locking code has been entered will lock all the settings effecting ARC communication (see the sequence list in section 5).
- If ARC programming is locked, then it can be **temporarily enabled** in service mode by entering **900 xx..x \*0** where xx..x is the locking code. It will then relock on exiting service mode.
- The ARC settings can be **permanently unlocked** by entering 901\*0 while ARC programming is temporarily enabled – see above. This will erase the locking code.

**Factory default setting:** ARC settings unlocked

## 6. LAN network configuration

Each device in an Ethernet network (LAN, internet) has its own IP address (e.g. 192.168.250.20). This address can either be a public or private one. Before connecting the LAN network cable, setting up the LAN network should be done – either by automatic DHCP or manually (see 5.16).

- If automatic DHCP is used, contact your network supervisor and ask him to make the network ready for the communicator. If he needs the communicator MAC address you will find it on the label attached to the communicator board.
- Manual programming of the network parameters should be done by a network supervisor who knows how to program these parameters.

## 7. Further guidance on the communicator

### 7.1. How the communicator sends reports

If there is a need to report an event (e.g. an alarm) then the communicator:

- sends data to ARC1, if used (the communicator tries the main IP address, if unsuccessful then it tries the backup IP address).
- Then it sends data to ARC2 in the same way if programmed as an independent ARC. If ARC2 is programmed as the backup to ARC1 then the data will only be sent to it if transfer to ARC1 has been unsuccessful.
- Then the unit sends SMS reports (1<sup>st</sup> tel. number, 2<sup>nd</sup> tel. number ....8<sup>th</sup> tel. number)
- Then the unit performs reporting by phone call (1<sup>st</sup> tel. number, 2<sup>nd</sup> tel. number ....8<sup>th</sup> tel. number) – each programmed number is called once whether the call has been answered or not
- If all previous attempts to send data to ARCs have been unsuccessful, the next attempts occur after the programmed repeat period (see 5.24).

If an alarm is cancelled by a user while it is being reported, any unsend SMSes and unperformed call reports are cancelled, but the ARC still gets a complete set of reports about events in the system.



## 7.2. The communicator's LEDs

Green LED:

- regular flashing – communication in progress (ARC, SMS or remote access)
- off – data is waiting to be sent to an ARC
- lit permanently – no waiting data to be sent to an ARC

Red LED:

- off – communication to the ARC is OK
- lit permanently – impossible to send data to any ARC

Yellow LED:

- regular flashing – Ethernet connected, DHCP is not working
- off – Ethernet is not connected
- lit permanently – Ethernet connected and communication with the network is OK

## 7.3. After entering service mode the communicator:

- finishes reporting to ARCs (if any is needed)
- unfinished SMS and call reports are cancelled
- unsent ARC reports are only erased if ARC tel. numbers / IP addresses or the ARC communication format or the installation ID are changed
- alarm restoration reports or fault restoration reports are sent to the ARC even in service mode
- changes to communicator settings do not take effect until service mode has been exited

## 7.4. Configuring the communicator in maintenance mode

If configuring the communicator in maintenance mode is enabled (via control panel programming), then the above described programming sequences can be used to set:

- tel. numbers M1 to M7
- the events reported by SMS and phone calls

## 7.5. Remote access by Internet

The system can be accessed remotely via [www.GSMLink.cz](http://www.GSMLink.cz) which allows complete programming by installers and also operating the system by end users. To access the system remotely it is necessary to:

- Have the communicator connected to an Ethernet network which allows access to [www.GSMLink.cz](http://www.GSMLink.cz)
- Register the communicator via the GSMLink web page by:
  - displaying [www.GSMLink.cz](http://www.GSMLink.cz) and selecting **New registration**
  - setting your login details (name and password)
  - entering the communicator registration code (see the communicator label)
  - entering your system access code (user or service – this gives you access to the user menu or the installer menu accordingly)
  - after entering the above parameters it should be possible to establish a connection with the system.

*If your communicator is using a dynamic IP address when communicating with the GSMLink server, then it could be that you will have to wait for a connection (if your IP address has been changed). GSMLink will indicate how long it will take to get connection with the system. To shorten the waiting time it is possible to initialise the communication remotely by dialling from a telephone which has been programmed for this function (see 5.9.1).*

- for further access sessions you only need to enter your login details (these can be memorized by your web browser)
- several people can register for internet access to the system (both installers and users)
- A service technician needs only one set of login details to access various installations. After the first system has been registered, the installer can add (or remove) other installations to(or from) his/her GSMLink account.
- there is a demo version of remote access on [www.GSMLink.cz](http://www.GSMLink.cz)
- using [www.GSMLink.cz](http://www.GSMLink.cz) is free of charge

## 7.6. A complete list of CID reports to ARCs

A report to an ARC consists of: installation ID, event code, subsystem number and the number of the source (device or code). In IP CID and SMS CID, in addition to this, a time stamp is also sent as follows.

## List of the CID reports

CID code	Event	ec
1130 / 3130	Intruder alarm – instant / restored	1 / 9
1134 / 3134	Intruder alarm – delayed / restored	2 / 9
1110 / 3110	Fire alarm / restored	3 / 9
1120 / 3120	Panic alarm / restored	4 / 9
1461 / 3461	Number of incorrect code-entries exceeded alarm / restored	5 / 9
1140 / 3140	Alarm triggered during control panel power-up / restored	6 / 9
1137 / 3137	Tamper alarm / no tampering	7 / 8
1144 / 3144	Device tamper alarm / no tampering	7 / 8
1406	Alarm cancelled by user	10
1401 / 3401	Unsetting / setting	12 / 11
3402	Partial setting	13
3408	Codeless complete setting	14
1354 / 3354	External communication fault / restored	15 / 16
1300 / 3300	Fault (except device) / all faults restored	17 / 18
1330 / 3330	Device fault / all faults restored	17 / 18
1301 / 3301	Mains dropout longer than 30 minutes / restored	19, 20 / 21
1302 / 3302	Battery fault (except devices) / all battery faults restored	22 / 23
1384 / 3384	Device battery fault / all battery faults restored	22 / 23
1306 / 3306	Switching to Service Mode / Leaving Service mode	24 / 25
1661 / 3661	PGX ON/OFF	26
1662 / 3662	PGY ON/OFF	27
1355	Radio communication jamming present	28
1350 / 3350	Internal communication fault / restored	29 / 30
1602	Communication test	31
1138	Unconfirmed alarm	32
1351	Communication fault to ARC1	to ARC2 if backups
1393	Annual check request	17
1551 / 3551	Communicator blocked / restored	31 only in IP CID

## List of source numbers

Source number	Source
701	Control panel
731	Communicator
741	Wired keypad
001 - 050	Devices 01 - 50
500	Master code
599	Service code
501 - 550	Codes 01 - 50

Subsystem: 01 in all reports

In a split system, for setting and unsetting: 02 = A, 03 = B

For partial setting: 02 = A, 03 = AB

## 8. Technical specifications

Power	12V DC (from the control panel)
Stand-by consumption	about 35 mA
Max. consumption (during communication)	1 A
Complies with	EN 50131-1/2006, EN 50136-1-1, 2-1 as: <b>ATS 4</b> if the ARC comm. repeating period is zero (sequence 06a0) <b>ATS 5</b> if ID CID protocol is used and the repeating period is set to zero (sequence 06a0)
Operating environment (–10 to 40°C)	class II
Safety	EN 60950
EMC	EN 55022, EN 5030-4
Radio transmissions	ETSI EN 301419-1 and EN 301511
CLIP protocol (caller ID + SMS)	ETSI EN 300 089 V3.1.1(2000-12)



Jablotron Ltd. hereby declares that the JA-80V is in compliance with the essential requirements and other relevant provisions of Directive 1999/5/EC. The original of the conformity assessment can be found at [www.jablotron.com](http://www.jablotron.com), - Technical Support section



**Note:** Although this product does not contain any harmful materials we suggest you return the product to the dealer or directly to the producer after use.



Pod Skalkou 33  
466 01 Jablonec nad Nisou  
Czech Republic  
Tel.: +420 483 559 999  
fax: +420 483 559 993  
Internet: [www.jablotron.cz](http://www.jablotron.cz)