

# UNIFIRE

## Monitors



the future of firefighting™

# Contents

<b>Force Monitors</b>	<b>1</b>
<b>Force50</b>	<b>2</b>
<b>Integ50 Nozzle</b>	<b>3</b>
<b>Flow &amp; Reach</b>	<b>4</b>
<b>Force80</b>	<b>5</b>
<b>Integ80 Nozzle</b>	<b>6</b>
<b>Flow &amp; Reach</b>	<b>7</b>
<b>Force Nozzle Options</b>	<b>8</b>
<b>Unifire PI Joystick</b>	<b>9</b>
<b>U-50 Manual</b>	<b>10</b>
<b>Monitor Control Systems</b>	<b>11</b>



# Force Monitors



Unifire designed its Force™ monitors in the 21st Century with a clear vision in mind--to create the world's most advanced, high-performance firefighting monitor, period.

Precision engineered and manufactured in Sweden to the highest possible standards of quality at ISO Certified facilities, Force monitors truly represent the future of firefighting.

In every detail the Force series is designed to be effective, reliable, robust, easy to use, simple to maintain, service and troubleshoot.

But that's not all. Force monitors are accompanied by Unifire's cutting-edge electronic control systems that take firefighting to a whole new level. Force monitors can be networked not only with each other, but with virtually any electronic device, including CCTV and infrared cameras, flame detectors, valves, lights, alarms, and much more.

Unifire's advanced electronics allow us to offer what are undoubtedly the most advanced automatic systems that utilize monitors.

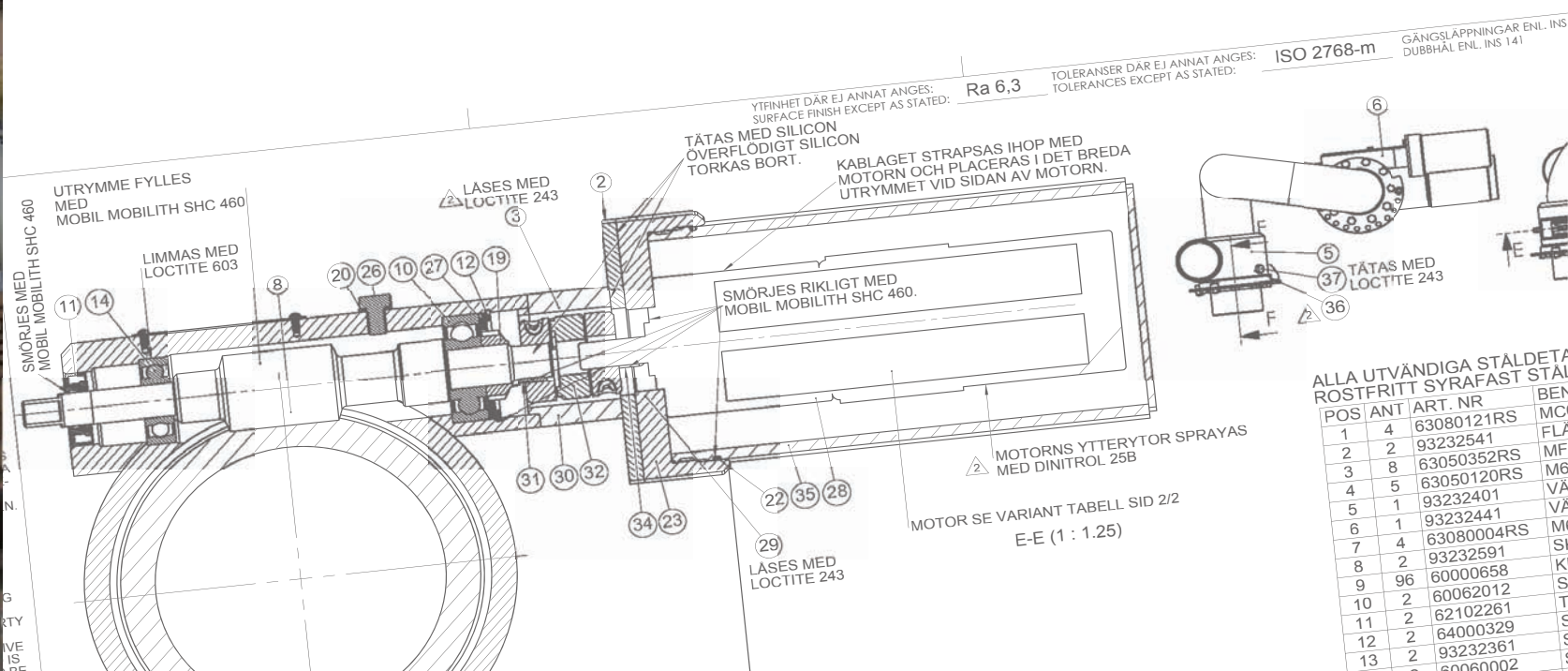



# Force50™

## Technical Specifications

Material:	Stainless Steel 316L (bronze gears)
Flow Range @ 10 bar / 145 psi:	400-2000 lpm / 100-530 gpm
Horizontal movement (max.):	360° (+/-180° from center)
Vertical movement (max.):	180° (+/-90° from horizontal)
Rotational velocity (max.):	20°/second (40°/second optional)
Vertical movement velocity:	12°/second
Fox angle with Integ50 (max.):	120°
Dimensions with Integ50 nozzle:	51 x 35 x 22 cm
Weight with Integ50 nozzle:	18.5 kg / 41 lbs.
Ambient operational temperature:	-25°C to +70°C / -13°F to 158°F
Power consumption normal/max. (@24V):	5-15 Amps
Voltage:	12- or 24V DC
Cable length Monitor-MCU:	5 Meters / 16 Ft.
Max. Joystick Cable Length:	Unlimited
Internal pipe diameter:	50 mm / 2 inches
Communication Protocol:	CANBUS
Maximum recommended pressure:	10 bar / 145 psi
Monitor base connection:	2" Male BSP
Nozzle connection:	2" Male BSP
Multi-connectors on all connection points:	YES
Supports Multiple Joysticks:	YES
Auxiliary control buttons:	YES (Two)
CE Marked:	YES
EMC Tested:	YES
Wireless radio remote option:	YES
Record / Play feature:	YES
Programmable park (stow) position:	YES
Soft stops automatically set:	YES
Adjustable hard stops:	YES
Software upgrade capable:	YES (manually)
Adjustable flow settings:	YES



Effective. Intelligent. Elegant. Reliable.

The Unifire Force50 is likely the most advanced remote controlled monitor of its class.

Compact, light weight and featuring fully-integrated gears and motors, the Force50 is ideal for land- and sea-based firefighting and industrial applications



# Integ50™ Jet/Spray Nozzle

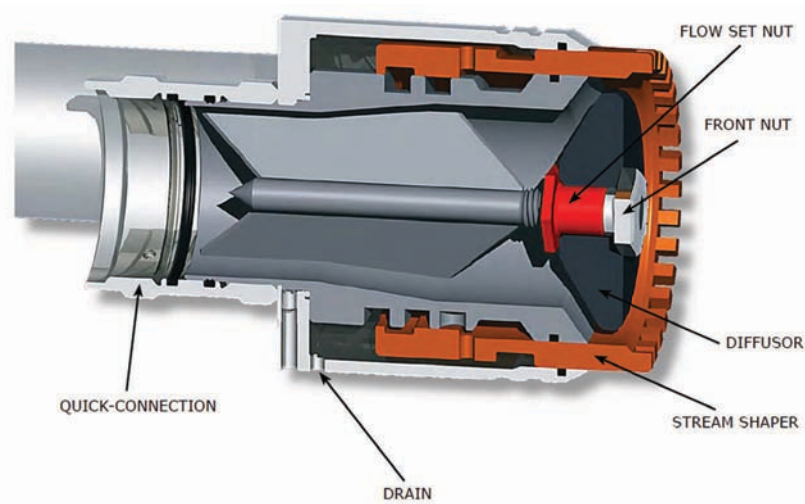

The Integ50 Nozzle is designed specifically for the Unifire Force50 monitors.

With an entirely integrated gear design and precision engineering, the Integ50 provides unbeatable performance in jet stream, full fog, and everything in between. With fully protected and uniquely integrated gear technology, the nozzle's motor and advanced gears are fully integrated into the nozzle with no external or exposed parts.

The Integ50's sleek appearance is matched by its intelligence. Precise knowledge of the nozzle's spray pattern position at all times provides the user with total control. This feature is also what gives Unifire's nozzles the ability to record exact spray patterns and play them back at the press of a single button.

## INTEG50 ADJUSTABLE FLOW SETTINGS

Flow is selected by adjusting the flow set nut of the nozzle, located behind the diffuser.

The flow is factory set to your specifications and can be adjusted and fine-tuned manually.

The flow set nut should, after adjustment, be locked with Loctite 243 or similar. The diffuser and front nut, pictured right, can be then remounted.



# FLOW & REACH of the Force50 with Integ50 Nozzle

## FLOWCHART FORCE 50 with INTEG50 nozzle

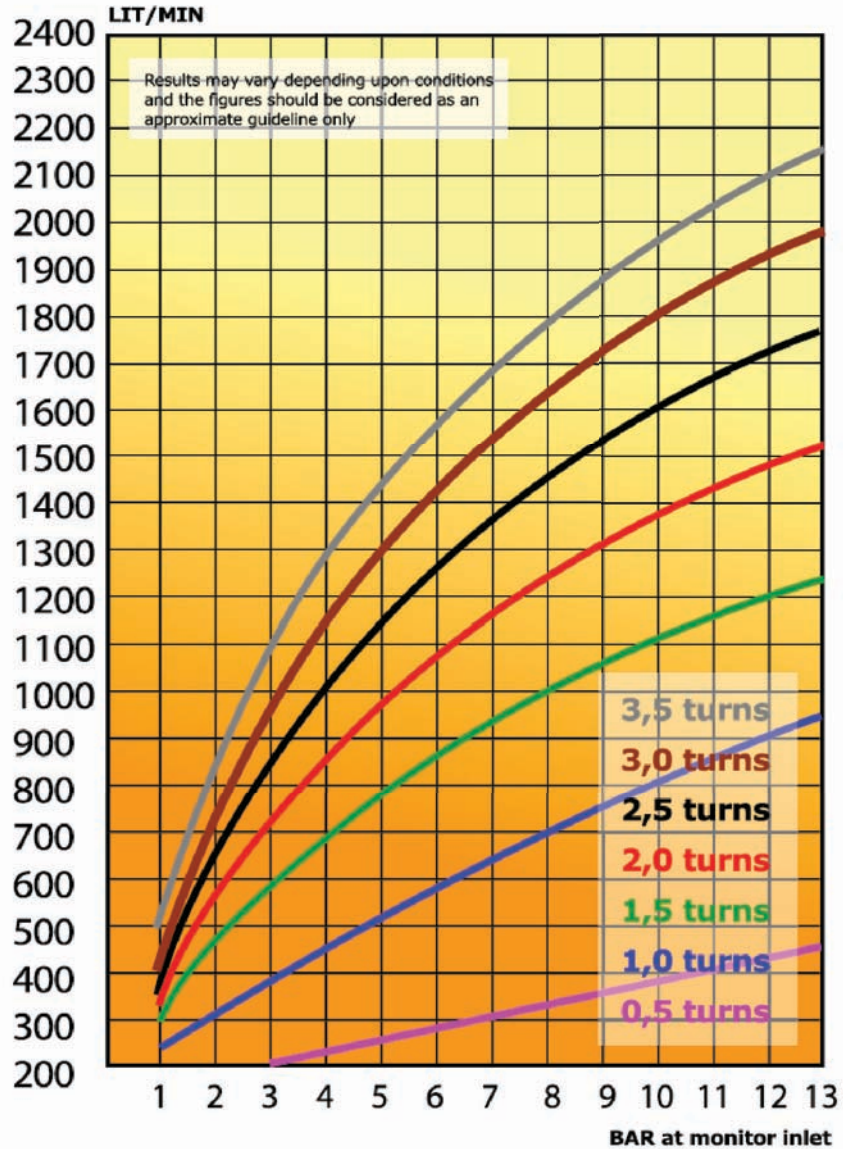

## REACH FORCE 50 with INTEG50 nozzle

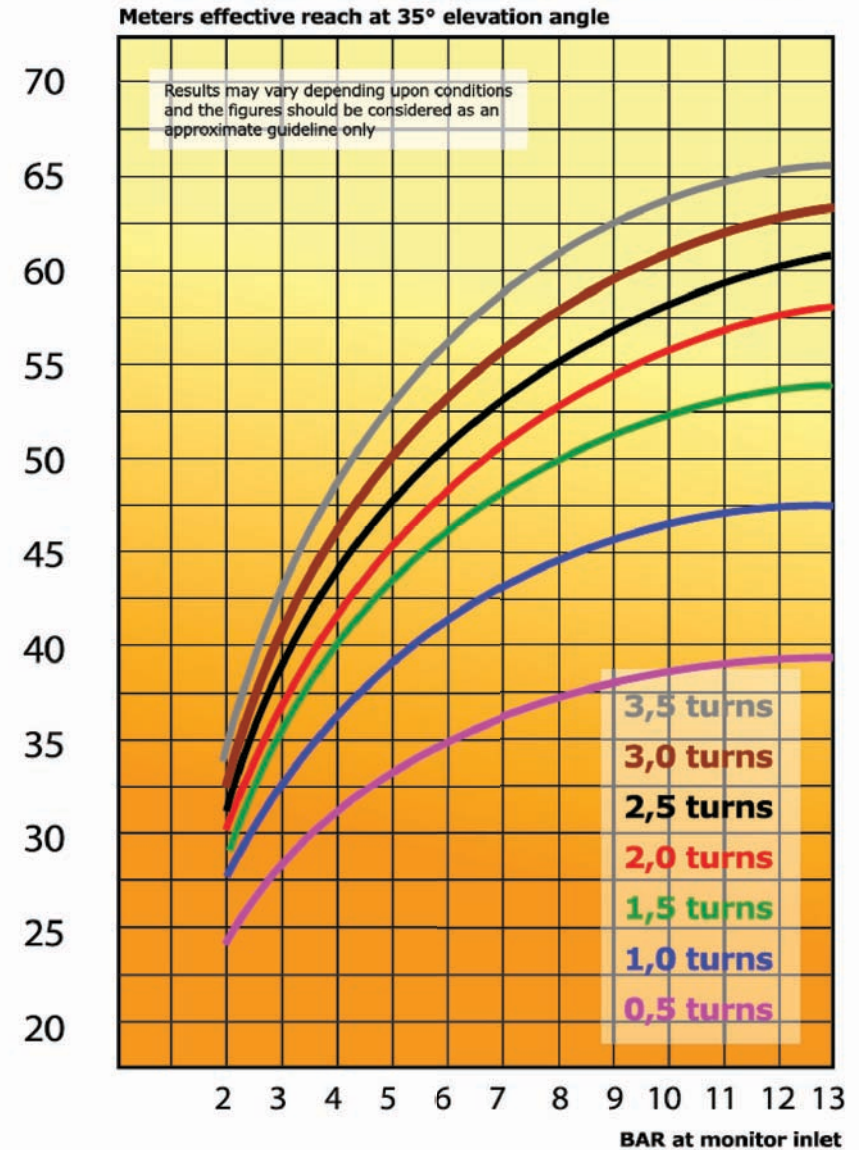



# Force80™

## Technical Specifications

Material:	Stainless Steel 316L (bronze gears)
Flow Range @ 10 bar / 145 psi:	2000 - 5000 lpm / 530 - 1320 gpm
Horizontal movement (max.):	360° (+/-180° from center)
Vertical movement (max.):	180° (+/-90° from horizontal)
Rotational velocity (max.):	12°/second (24°/second optional)
Vertical movement velocity:	8°/second
Fox angle with Integ80 (max.):	120°
Dimensions with Integ80 nozzle:	71 x 50 x 33 cm
Weight with Integ80 nozzle:	30 kg / 66 lbs.
Ambient operational temperature:	-25°C to +70°C / -13°F to 158°F
Power consumption normal/max. (@24V):	5-15 Amps
Voltage:	24V DC
Cable length Monitor-MCU:	5 Meters / 16 Ft.
Max Joystick Cable Length:	Unlimited
Internal pipe diameter:	80 mm / 3.15 inches
Communication Protocol:	CANBUS
Maximum recommended pressure:	10 bar / 145 psi
Monitor base connection:	3" Male BSP
Nozzle connection:	3" Male BSP
Multi-connectors on all connection points:	YES
Supports Multiple Joysticks:	YES
Auxiliary control buttons:	YES (Two)
CE Marked:	YES
EMC Tested:	YES
Wireless radio remote option:	YES
Record / Play feature:	YES
Programmable park (stow) position:	YES
Soft stops automatically set:	YES
Adjustable hard stops:	YES
Software upgrade capable:	YES (manually)
Adjustable flow settings:	YES

The Unifire Force80 is a high-performance, masterfully-engineered and highly intelligent remote controlled water/foam monitor.

Intuitive, precise control is achieved by the monitor's progressive controls, ranging from its zippy full speed to get right to the target, to slower and slower for accurate targeting. All regulated naturally depending on how forcefully you press the joystick shaft in any direction.

Light weight, sleek and robust, the Force80 is ideal for firefighting and industrial applications of virtually all types, both on and off shore.

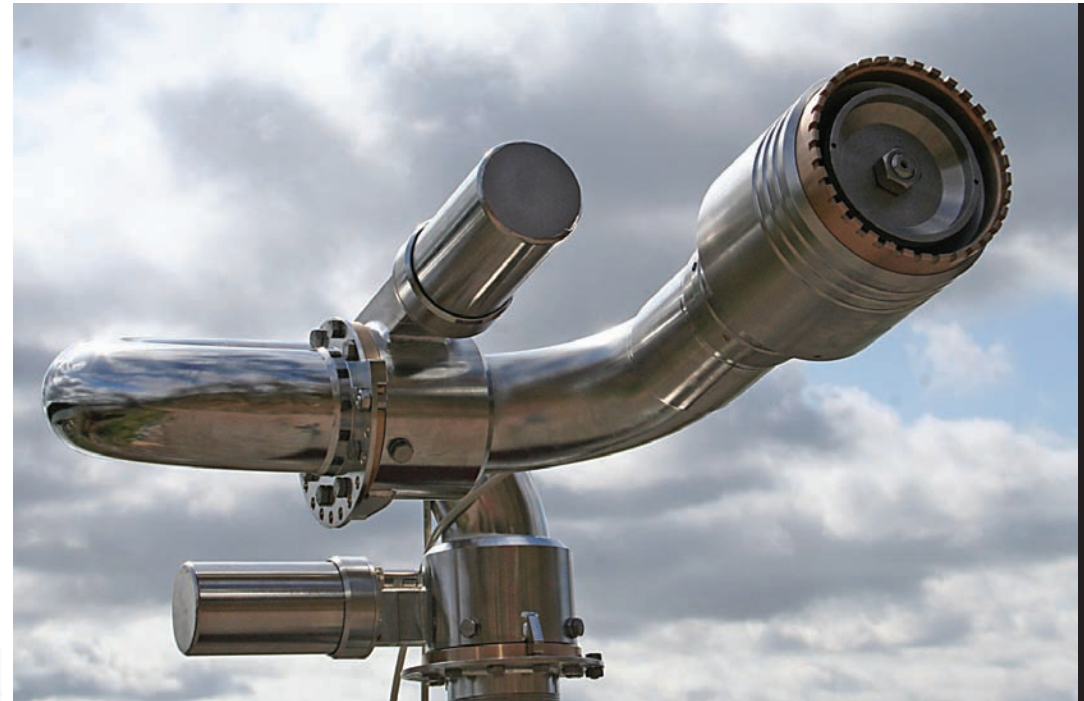

# Integ80™ Jet/Spray Nozzle

The Integ80 jet/spray nozzle offers superior spray angle control and firefighting capabilities.

Designed exclusively for the Unifire Force80 remote controlled monitors, the Integ's spray pattern is controlled simply and intuitively by twisting the head of the Unifire joystick shaft until you achieve the precise angle desired.

With fully protected and uniquely integrated gear technology, the nozzle's motor and advanced gears are fully integrated into the nozzle with no external or exposed parts.

Intuitive, precise control is achieved via the monitor's progressive controls ranging from fast, full speed to quickly get to the target, then down slower and slower to extremely slow, accurate targeting.

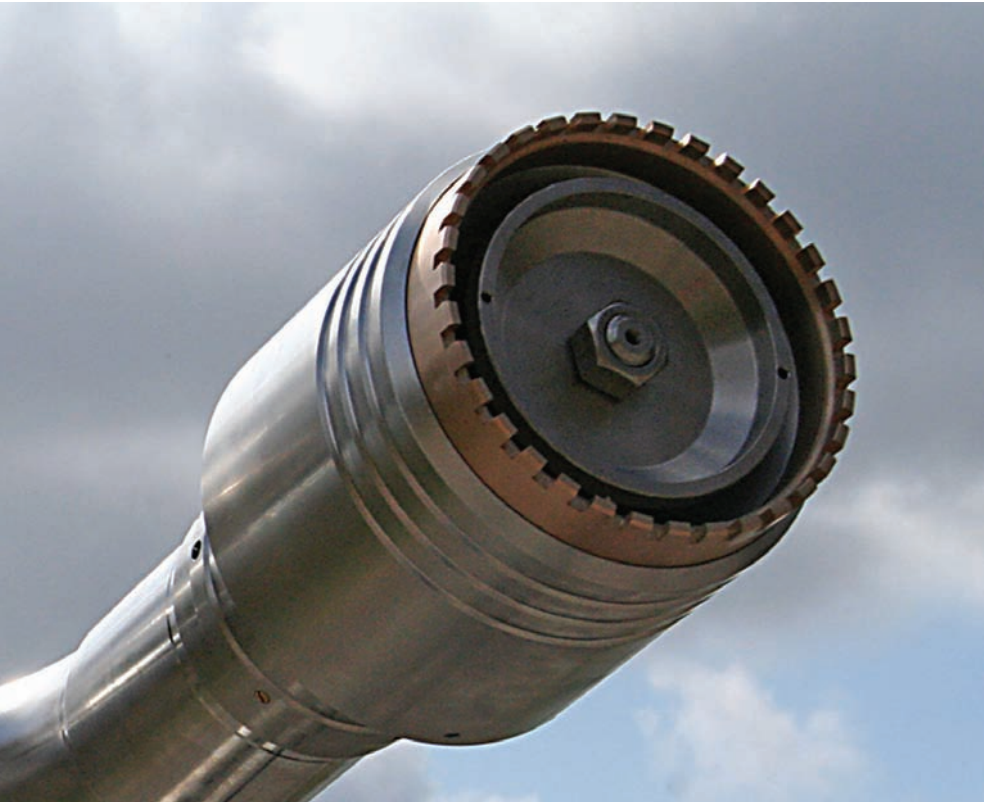

Integ80 Adjustable Flow.

Flow is selected by adjusting the baffle and tightening the safety nut.

The flow is factory set to your specifications and can be adjusted and fine-tuned manually to optimize performance on site.

Performance is required under the most extreme conditions of firefighting. The Integ80 delivers the ultimate in nozzle performance, on land and at sea.

Expect the Unexpected!



## FLOW & REACH of the Force80 with Integ80 Nozzle

### FLOW FORCE 80 with INTEG 80 nozzle

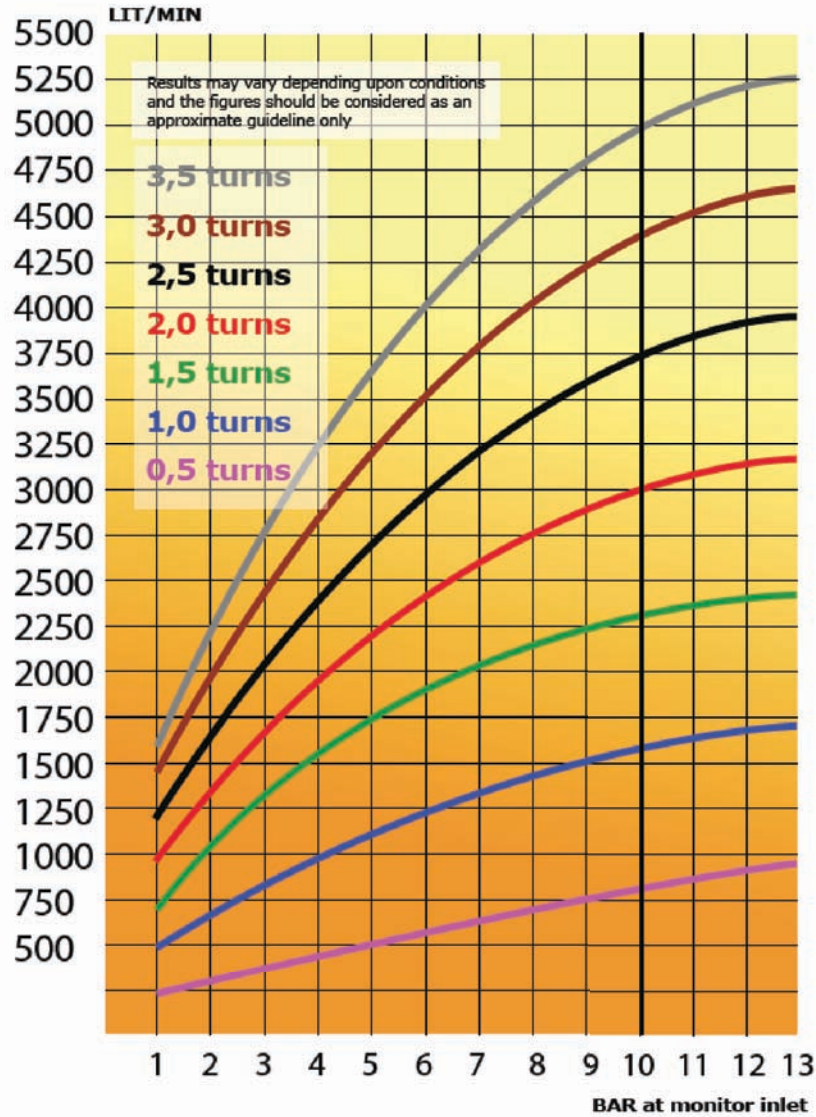

### REACH FORCE 80 with INTEG 80 nozzle

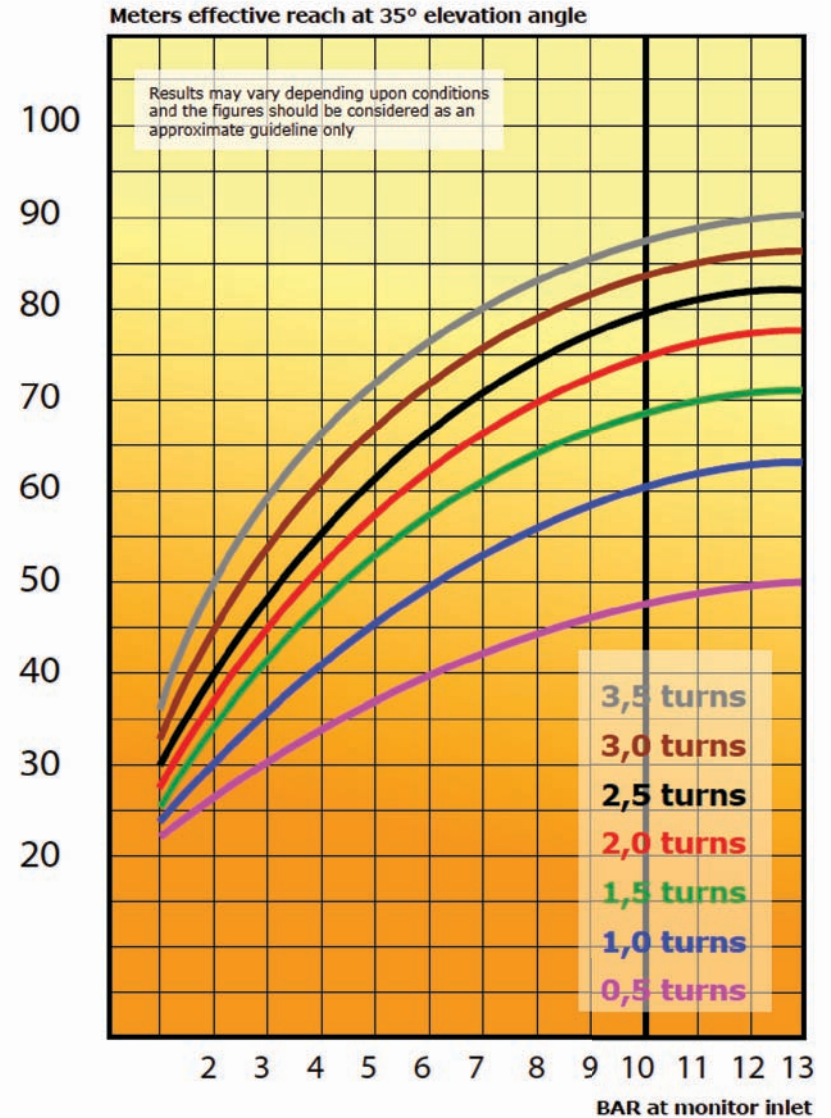

*Unifire Force50 with Smooth Bore Nozzle*



# FORCE Nozzle Options

## NOZZLE SOLUTIONS TO GET THE JOB DONE

Specializing in manufacturing high-quality nozzles since 1969, Unifire offers nozzle solutions for a variety of firefighting and industrial applications.

Unifire offers the Integ jet/spray nozzles as well as smooth bore nozzles, foam, and dry-chem nozzle options to meet your needs.

Both the Force50 and Force80 monitor chassis feature common BSP thread connections for easy fitting of a variety of nozzles made by Unifire and third parties alike (such as the dry-chem nozzle by Williams Fire & Hazard Control, Inc., pictured, right).

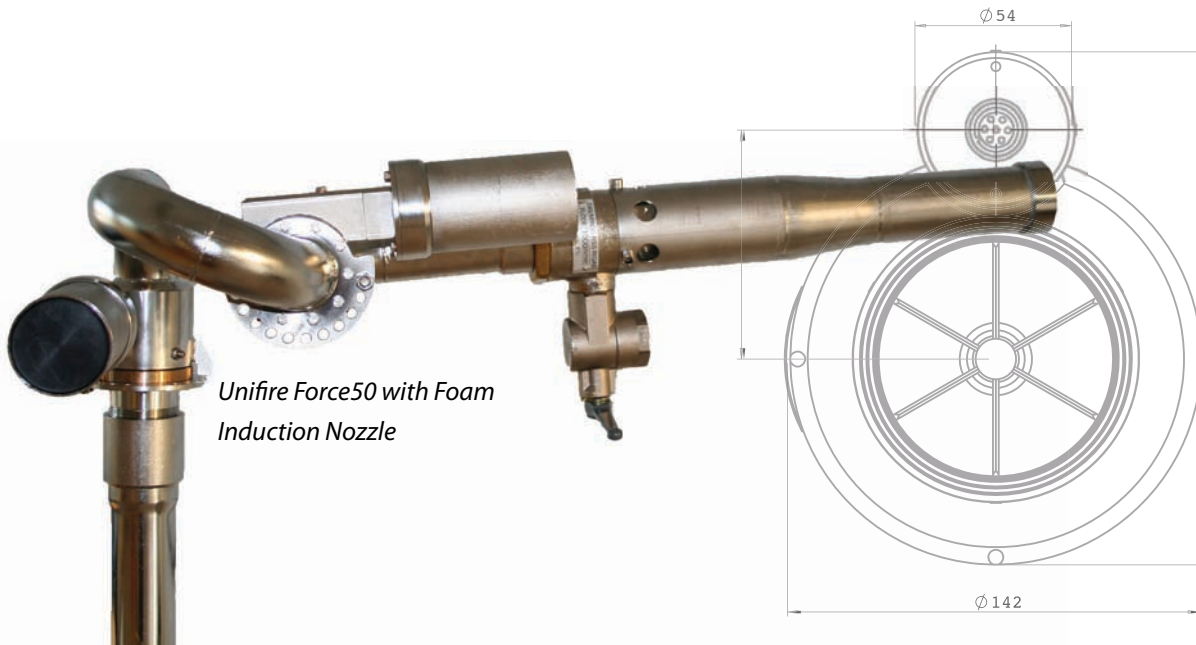

*Unifire Force50 with Foam Induction Nozzle*



*Unifire Force80 with Smooth Bore Nozzle*

# U-50™

## Manually Operated Monitor



Material: Stainless Steel 316L

Flow Range @ 10 bar / 145 psi: 400 - 1500 lpm / 100 - 400 gpm

Horizontal movement (max.): 360° (+/-180° from center)

Vertical movement (max.): 180° (+/-90° from horizontal)

Adjustable Limit Bolts: YES (horizontal & vertical)

Dimensions: 54 x 27 x 30 cm

Weight with U-Nozzle: 7 kg / 15½ lbs.

Monitor Base Connection Size: 2" Male BSP

Nozzle Connection Size: 2" Male BSP



The U-50 is a simple, proven monitor that has been saving lives for more than 35 years.

Its robust stainless steel construction and components make it ideal for all applications requiring a small, manually operated monitor, both on- and off-shore.

The U-50 can be delivered complete with the Unifire U-Nozzle™ (pictured left), a Unifire smooth bore nozzle (pictured below), with Unifire's V20 Nozzle (pictured bottom, left), or can be outfitted with any 2" BSP nozzle connection or fire coupling. This allows the monitor to utilize virtually any hand-line nozzle or foam pipe.

The efficient, smooth design of the U-50 provide superior, reliable performance year after year.







## π

the ultimate firefighting joystick™

The Unifire π ("PI") Joystick is an all-new, intelligent joystick that is light-weight and simple to use, even under the stress of fighting fires.

With built-in monitor position indicators right on the joystick, progressive control from ultra slow and precise to increasingly faster to full speed, the ability to change the spray pattern by simply twisting the tip of the joystick shaft, to control of valves and other peripherals and even stowing... the π joystick represents the latest generation in joystick technologies.

- Light Weight (≈1.2 Kg / 2½ Lbs.)
- Record & Play Buttons (Full, Natural Record)
- Progressive Control For Precise Targeting
- One-Hand Operation
- Monitor Position Indicator LED's
- Spray Pattern Indicator LED
- Valve On/Off Button
- Two Auxiliary Buttons (For Valves, Lights, etc.)
- Park Button (Programmable)
- Highly Water Resistant
- Multi-Connector At Base
- "Twist Top" For Simple Spray Pattern Control
- Led Lights To Indicate Status



# MONITOR CONTROL SYSTEMS



Unifire's advanced control systems make them ideal for not only a wide variety of traditional firefighting applications, but also provide powerful capabilities of managing entire networks of Unifire monitors, detectors, cameras, alarms, valves, lights, joysticks, radio remote controls and other peripheral devices.

The Unifire Control System™ is designed specifically for networked solutions. Unifire custom designs systems to meet its client's needs to control the variety of equipment that goes into modern firefighting installations.

The FlameRanger™ is Unifire's newest and most advanced control system. Designed specifically to operate with cutting-edge infrared and flame detection technologies to interpret their signals, triangulate a fire's position and control Force monitors on a network, the FlameRanger offers eerily-advanced firefighting capabilities.

Unifire's Monitor Control Unit (MCU, pictured left) is the brain behind Unifire's advanced Force monitors, and interfaces with other Unifire control systems (I/O cards, UCS, FlameRanger, etc.)





**UNIFIRE**

UNIFIRE AB • Bultgatan 40B • 442 40 Kungälv • Sweden

Tel +46 303 248 400 • sales@unifire.com

[www.unifire.com](http://www.unifire.com)